

MJ 邁鈞機械工業股份有限公司

LP-660CM504-V2T下擺式球心型高速研磨機
(光學鏡片加工用)

BOTTOM SWING & SPHERICAL CENTER TYPE HIGH SPEED
GRINDING MACHINE (OPTICAL LENS PROCESSING)



各軸單動

Individual axle
control

邁鈞機械工業股份有限公司
MAI JIUN MACHINERY CO., LTD

412-80 台灣台中市大里區仁化里工業十路8號
NO. 8, GONGYE 10TH RD., RENHUA LI,
DALI DIST, TAICHUNG CITY 412-80, TAIWAN.
TEL: 886-4-24912698 FAX: 886-4-24915811
E-mail: mai.j.mail@msa.hinet.net

660 R50

660(R50)下擺式球心型高速研磨機(光學鏡片加工用)-機台規格表 SPECIFICATION

A01

機型	Type	LP-660CM504-V2T
軸數	Axle number	4 軸 4axis
控制方法	Control method	各軸單動 Individual axle control
加工範圍	Processing range	φ1~ φ35
鏡片加工最大 R 值	Lens to process Max. R	凹凸皆為 1~50Rmm Concave & Convex→1~50Rmm
擺動角度	Swing angle	0°~ 40° (隨研磨 R 值與擺動角度做變更) (With grinding R value and swing angle to do alteration)
調整角度	Adjustment angle	0°~ 45° (隨研磨位置與擺動角度做變更) (With grinding position and swing angle to do alteration)
主軸轉速	Shaft speed	640~3500R.P.M(無段變速) (Stepless speed)
擺動速度	Swing shaft speed	0~45CPM(無段變速) (Stepless speed)
壓力源範圍	Pressure range	0~10kgf
電源使用	Power supply	依各地電壓使用 According to different voltage
電路系統	Electric system	基本電路 Basic circuit
定寸裝置	Thickness survey device	有 use
補償裝置	Compensate device	無 No use
馬力/安培	kW/A	1.8 kW /8.2A
給水裝置	Water supply device	雙泵 Double pump
加工水槽	Processing water trough	四槽 Four trough
真空吸引	Vacuum Attract	有 use
機械重量	Machine weight	1130kg
機械體積 長×寬×高	Machine dimension L×W×H	1842×1055×1749
機台特色 Feature of machine	*本系列機台可二段式速度設定 *These series machine are dual speed setting. *本機自轉軸軸心之軸徑尺寸為φ6mm *The diameter for the spindle of rotation axle is φ6mm. *上軸升降使用線性滑軌。 *Upper shaft lifting up & down by linear guideway.	

20

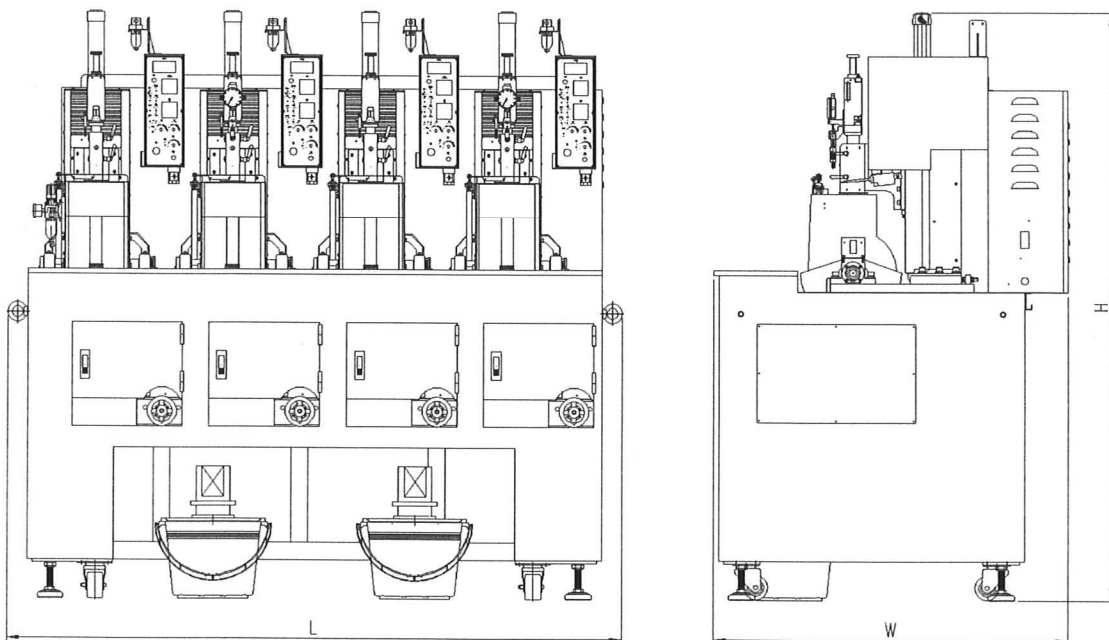

660(R50)下擺式球心型高速研磨機(光學鏡片加工用)-機台規格表 SPECIFICATION

A01

機型	Type	LP-660CM504-V
軸數	Axle number	4 軸 4axis
控制方法	Control method	各軸單動 Individual axle control
加工範圍	Processing range	φ1~ φ35
鏡片加工最大 R 值	Lens to process Max. R	凹凸皆為 1~50Rmm Concave & Convex→1~50Rmm
擺動角度	Swing angle	0°~ 40° (隨研磨 R 值與擺動角度做變更) (With grinding R value and swing angle to do alteration)
調整角度	Adjustment angle	0°~ 45° (隨研磨位置與擺動角度做變更) (With grinding position and swing angle to do alteration)
主軸轉速	Shaft speed	640~3500R.P.M(無段變速) (Stepless speed)
擺動速度	Swing shaft speed	0~45CPM(無段變速) (Stepless speed)
壓力源範圍	Pressure range	0~10kgf
電源使用	Power supply	依各地電壓使用 According to different voltage
電路系統	Electric system	基本電路 Basic circuit
定寸裝置	Thickness survey device	無 No use
補償裝置	Compensate device	無 No use
馬力/安培	kW/A	1.8 kW /8.2A
給水裝置	Water supply device	雙泵 Double pump
加工水槽	Processing water trough	四槽 Four trough
真空吸引	Vacuum Attract	有 use
機械重量	Machine weight	1130kg
機械體積 長×寬×高	Machine dimension L×W×H	1842×1055×1749
機台特色 Feature of machine	*本系列機台可二段式速度設定 *These series machine are dual speed setting. *本機自轉軸軸心之軸徑尺寸為φ6mm *The diameter for the spindle of rotation axle is φ6mm. *上軸升降使用線性滑軌。 *Upper shaft lifting up & down by linear guideway.	

20

